



Model SD505-ADH Duct Smoke Detector



Detect smoke in air handling systems and air handling equipment with Silent Knight's addressable duct smoke detector

The SD505-ADH addressable duct smoke detector detects smoke and products of combustion present in air moving through an HVAC air handling system. The SD505-ADH is a heavy duty metal housing with a pre-installed detector base. When smoke is detected in a duct, the unit communicates the condition to the IntelliKnight control panel. The panel, in turn, depending on programming and wiring, turns off fans, blowers, and other devices.

The SD505-ADH is designed to be used with Silent Knight's SD505-APS Photoelectric Smoke Detector and SD505-AIS Ionization Smoke Detector. Now there's even more power and flexibility available to the IntelliKnight family of products!

Model SD505-ADH Duct Smoke Detector

The Model SD-505 ADH Duct Smoke Detector is a heavy duty metal detector housing with a pre-installed detector base. The unit is compatible with Silent Knight's SD505-APS photoelectric and SD505-AIS ionization smoke detectors.

All features of the photoelectric and ionization detectors are available, including automatic drift compensation for contamination and the automatic detector calibration test. Detector calibration can be checked from the panel or remotely (using the IntelliKnight software with a Windows™ based computer).

Operation

Air sampling is accomplished by two tubes which protrude into the duct. An exhaust tube of one standard length (7.5") is provided with the detector housing. Intake sampling tubes (ordered separately) are supplied in three standard lengths. Duct mounting is accomplished through a template and 4 sheet metal screws (provided).



Features

- Two-wire connection to SLC
- LED alarm indication and communication on sensor head
- Rugged steel backbox with clear plastic cover
- Installation template included
- Large terminal connection screws
- Interchangeable "plug-in" photoelectric or ionization heads
- 3 standard tube lengths
- UL listed, complies with NFPA 72 and 101
- CSFM listed
- MEA Approved 429-92-E, Vol 9
- FM Approved



**SILENT
KNIGHT**

Specifications

Included Parts:	Metal housing with 7.5" exhaust tube SD505-4AB detector base Installation template 4 mounting screws
Accessory models:	(parts not included with SD505-ADH)
SD505-APS	Photoelectric Smoke Det.
SD505-AIS	Ionization Smoke Det.
SD500-ARM	Relay Module
STS-2.5	Sampling tube for 6" to 2.5' duct width
STS-5.0	Sampling tube for 2.5' to 5.0' duct width
STS-10.0	Sampling tube for 5.0' to 10.0' duct width
Current:	.55 mA (alarm and standby)
Air Velocity:	500-4000 fpm (SD505-APS) 300-4000 fpm (SD505-AIS)
Sensitivity:	1.1 (SD505-APS) % obs 0.8 (SD505-AIS) % obs
Ambient Temperature:	32°F to 100°F (0°C to 37°C)
Humidity:	10 to 85% RH
Dimensions:	10" H x 8.25" W x 2.25" D
Color:	Gray

Model SD505-ADH

Duct Smoke Detector



Engineering Specifications

The air duct smoke detector shall be Silent Knight Model SD505-ADH. The housing shall contain a detector base, Silent Knight model SD505-4AB. The detector housing must be compatible with Silent Knight smoke detector head models SD505-APS (photoelectric) and SD505-AIS (ionization). One detector head must be used for each SD505-ADH used. The detector head must perform an automatic sensitivity check every 3 hours.

The duct detector housing shall be of metal construction. Complete mechanical installation must be able to be performed without removal of the detector cover. Terminal connections shall be screw type using a minimum of #6 screw.

SD505-ADH Dimensions

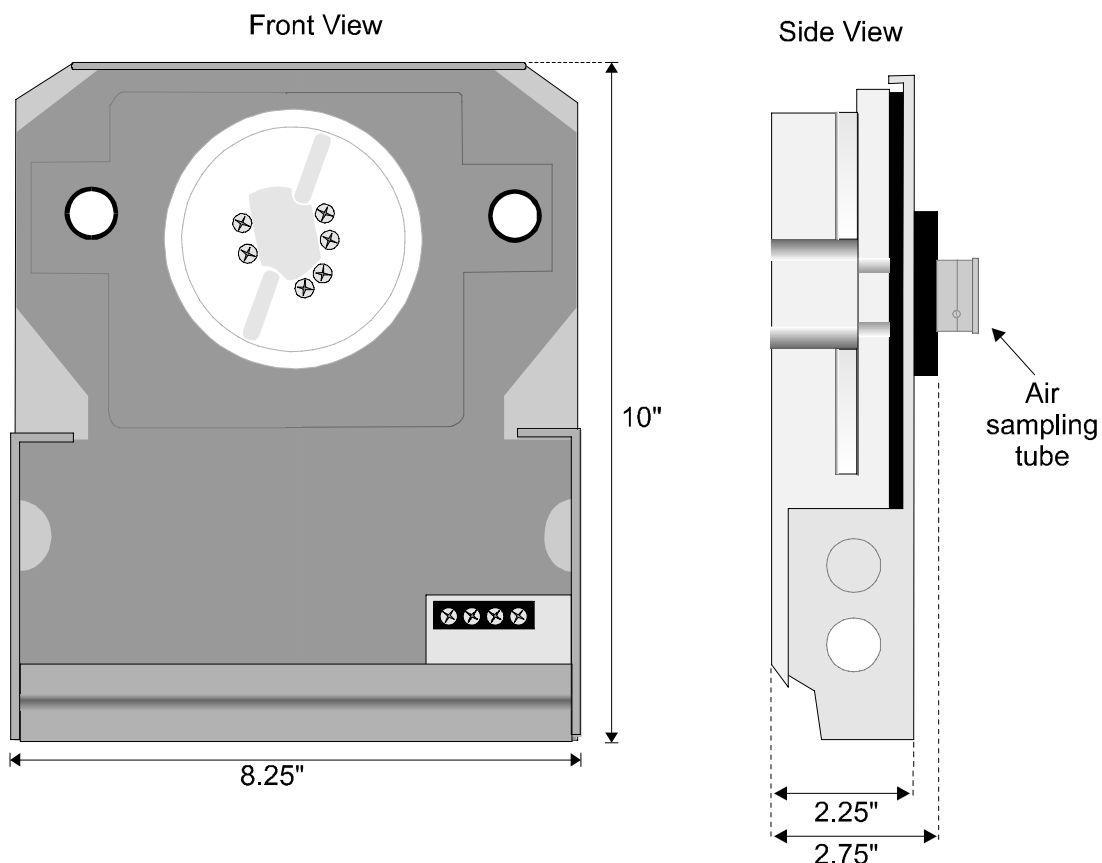

**SILENT
KNIGHT**

7550 Meridian Circle, Maple Grove, MN 55369-4927

800-446-6444 or in Minnesota 763-493-6435

FAX: 763-493-6475

World Wide Web: <http://www.silentknight.com>

MADE IN AMERICA

FORM# 350216, Rev. 01/01

Copyright © 2001 Silent Knight