



Addressable Photoelectric Type Smoke Detector



Detect smoldering fires quickly and get help fast with IntelliKnight® photoelectric smoke detectors.

IntelliKnight addressable photoelectric smoke detectors are the clear choice for commercial settings where smoldering fires are a threat. In addition to accurately detecting a smoldering fire, each SD505-APS photoelectric detector has a unique address, which is recognized by the IntelliKnight panel. No precious seconds are wasted in determining location of an alarm.

The SD505-APS compensates automatically for contamination in the environment. And detector testing is simple—even from a remote site. Like other IntelliKnight detector models, the SD505-APS offers a low profile for pleasing aesthetics. The IntelliKnight family of detectors has been designed to use a common base, Model SD505-6AB, allowing complete application and placement flexibility. Combine all this with the features you've come to expect from Silent Knight smoke detectors—easy installation, stable operation, RF/transient protection, and vandal-resistant locking—and it adds up to a flexible solution for all your fire protection needs.

Model SD505-APS Analog / Addressable Photoelectric Type Smoke Detector

The SD505-APS is particularly suited to detecting dense smoke typical of fires involving materials such as soft furnishings, plastic, foam or other similar materials which tend to smolder and produce large visible particles.

The detector features automatic compensation for contamination and a simple detector calibration test procedure that can be run from the panel or remotely (using the Windows™ based downloading software).

Operation

The SD505-APS units made up of an LED light source and a silicon photo diode receiving element. In a normal standby condition, the receiving element receives no light from the pulsing light source. In the event or fire, smoke enters the detector and light is reflected from the smoke particles to the receiving element.

The light received is converted into an electronic signal. Under normal conditions, the status LED blinks approximately every 15 seconds, indicating that the head is communicating with the loop. The LED lights continuously during the alarm period.

Features

- Low profile, 2 inches, including base
- Simple and reliable addressing without mechanical switches
- Automatic compensation for sensor contamination
- Built-in fire test feature
- Simple detector calibration testing through the control panel or remotely through a Windows™ based computer software.
- Vandal-resistance locking features
- Field cleanable
- UL listed, meets NFPA 72 Ch 7 requirements
- CSFM approved
- MEA approved
- FM Approved



SD505-APS Smoke Detector

Specifications

Operating Voltage:	17-41 VDC
Current Consumption:	
Standby:	.55 mA
Alarm:	.55 mA
Ambient Temperature:	32°F to 100°F (0°C to 50°C)
Mounting:	4" Square, 4" OCT, Single gang mud ring
Relative Humidity:	85% noncondensing
Air Velocity:	0 - 300 FPM
Compatible Bases: (Sold Separately)	SD505-6AB (6" Base) SD505-4AB (4" Base)



**SILENT
KNIGHT**

Model SD505-APS Addressable Photoelectric Type Smoke Detector



Engineering Specifications

The contractor shall furnish and install where indicated on the plans, addressable photoelectric smoke detector Silent Knight SD505-APS. The combination detector head, and twist-lock base, shall be UL® listed compatible with Silent Knight's IntelliKnight fire control panels.

The base shall permit direct interchange with Silent Knight SD505-AIS Ionization Smoke Detector, or SD505-AHS Heat Detector. Base shall be the appropriate twist-lock base SD505-6AB.

The smoke detector shall have a flashing status LED for visual supervision. When the detector is actuated, the flashing LED will latch on steady. The detector may be reset by actuating the control panel reset switch.

The calibration of the detector shall be capable of being selected and measured by the control panel without the need for external test apparatus.

The vandal-resistant, security locking feature shall be used in those areas as indicated on the drawing. The locking feature shall be field selectable as required.

The SD505-APS shall automatically perform a functional test of the detector. The test method shall simulate effects of products of combustion in the chamber to ensure testing of detector circuits.

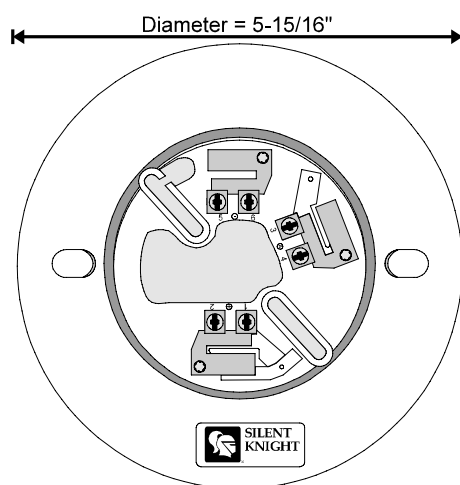

**Model SD505-6AB Detector Base
(front view)**

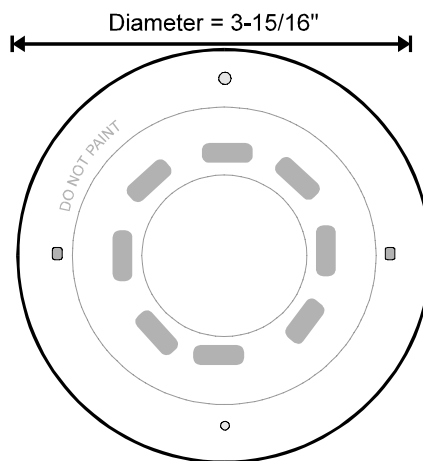

**Model SD505-APS Detector Head
(front view)**

Height = 2 inches,
including base



**SILENT
KNIGHT**

7550 Meridian Circle, Maple Grove, MN 55369-4927

800-446-6444 or in Minnesota 763-493-6435

FAX: 763-493-6475

World Wide Web: <http://www.silentknight.com>

MADE IN AMERICA

FORM# 350225, Rev. 12/01

Copyright © 2001 Silent Knight